

FUEL RETURN
8mm HOSE TAIL

FUEL BLEED SCREW

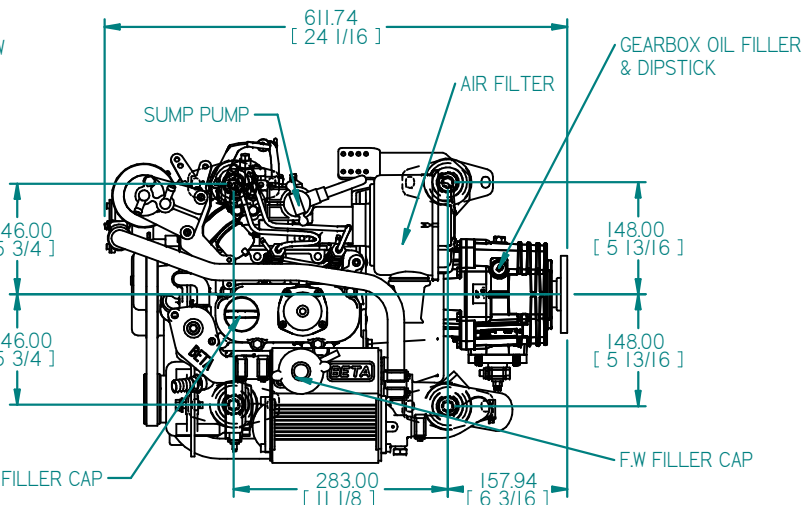

FLEXIBLE COUPLING DETAILS

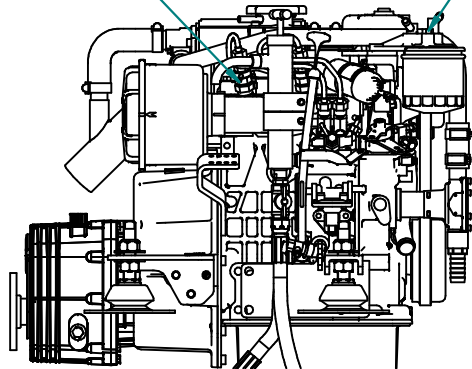
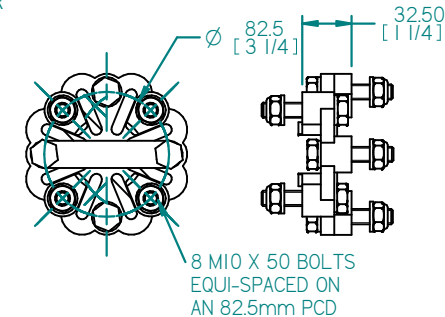

FLEXIBLE MOUNT DETAILS

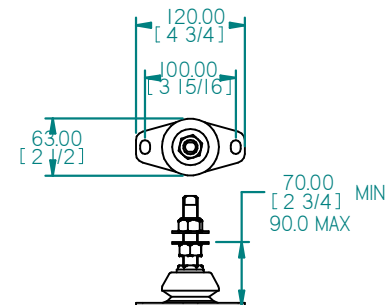

LUBE OIL
DIPSTICK

205.02 [8 1/16]

223.25 [8 13/16]

FROM CALORIFIER
5/8" BSP BORE HOSE
45 Amp 12V
ALTERNATOR

TO CALORIFIER
5/8" BSP BORE HOSE

SACRIFICIAL ANODE

OPTIONAL
HI RISE EXHAUST

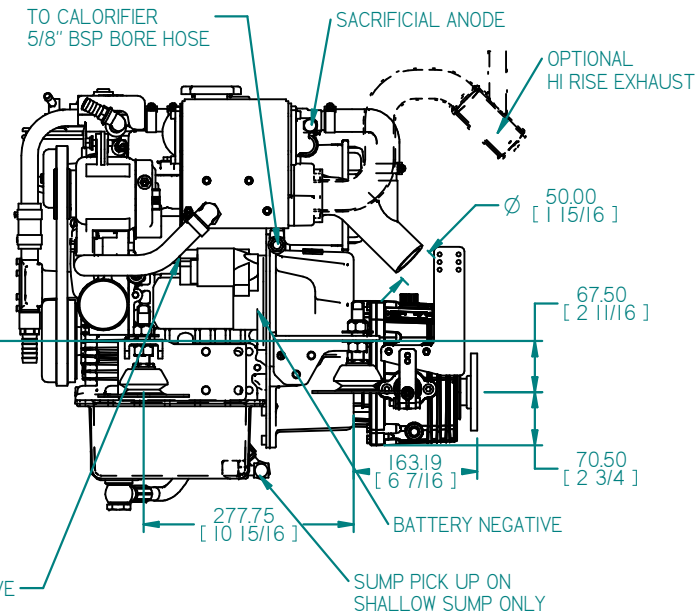
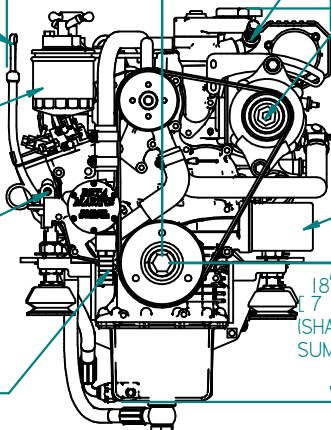

GEARBOX OUTPUT

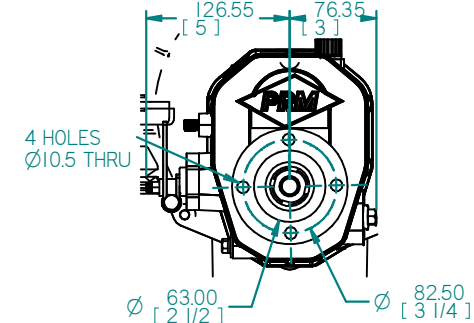

REV	DESCRIPTION	DATE	APP'D	DRAWN	NOTES
01					

TITLE:
**B16HE HEAT EXCHANGE
PRM60 GEARBOX & ATOMIC FEET**

DIMENSIONS IN MM (INCH)
DO NOT SCALE

PART FILE NAME: 202-20126 B16HE PRM60 ATOMIC FEET.asm

BETA MARINE

BETA MARINE LTD,
DAVY WAY,
WATERWELLS,
QUEDGELEY,
GLOUCESTER. GL2 2AD, UK

TEL: (01452) 723492 FAX: (01452) 729916

DRAWN BY: JLT
CHECKED BY: TW

SIZE A4
SCALE NTS

DWG NO: 100-20126
PAGE 1 of 1

REV 00
DATE 22/05/2018